

Wing 604-ED[®]

Dry Bulk Truck Compressor Driven by Diesel Engine

*High Performance
Light Weight
Quiet*

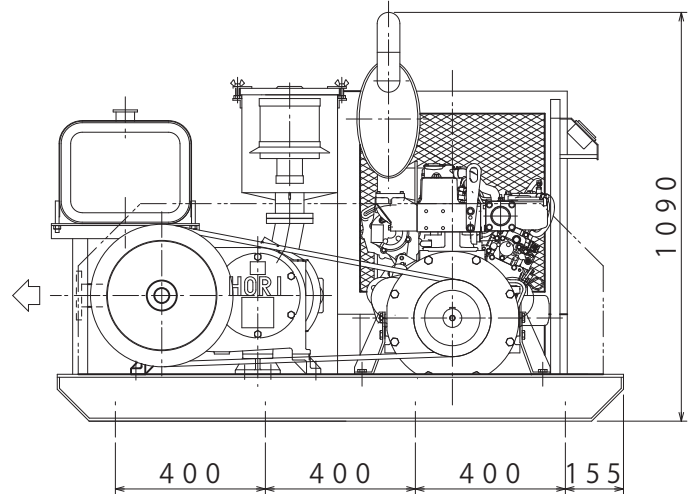
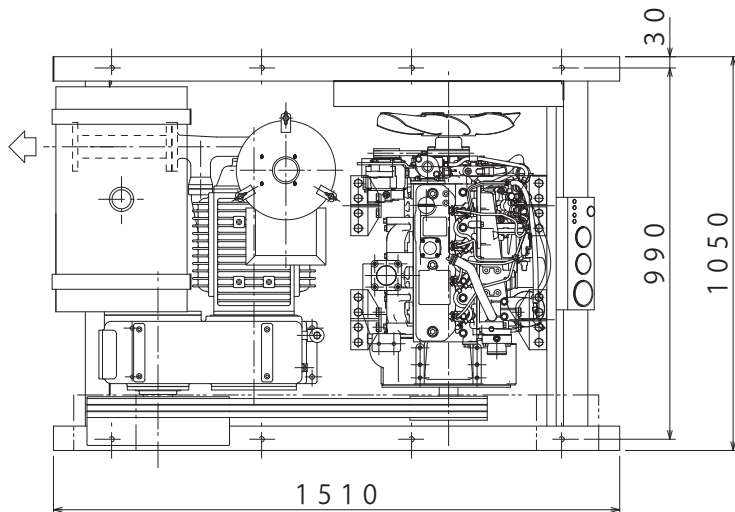
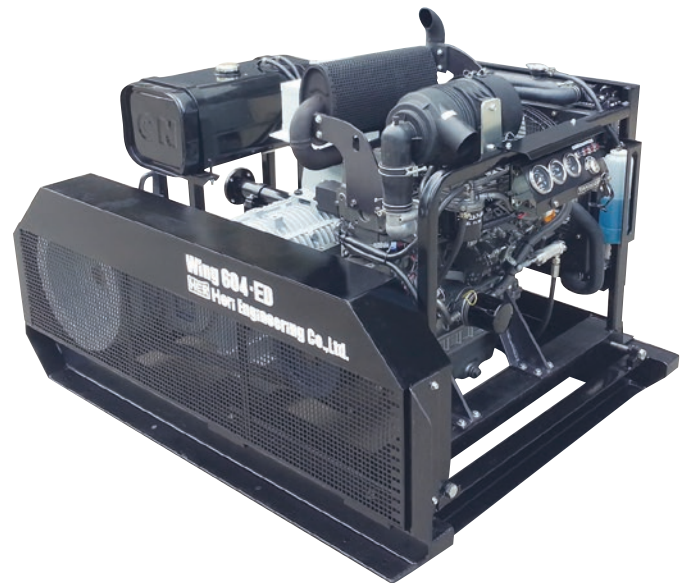

Specification

Max. Discharge Pressure	36 PSI (2.5 bar)
Discharge Pressure	30 PSI (2.0 bar)
Flow Rate	650 m ³ /hr
Weight	665 kg

HER Hori Engineering Co., Ltd.[®]

2285 Kuzuhara Fujisawa 2520822 Japan

TEL: 81-466-47-1000 E-mail: horieng@horieng.co.jp

FAX: 81-466-47-1075 URL: <http://www.horieng.co.jp/index.html>